

# Paranco figura 5. tipo ----- Hoist type ----- XM963NS2H20A/53a

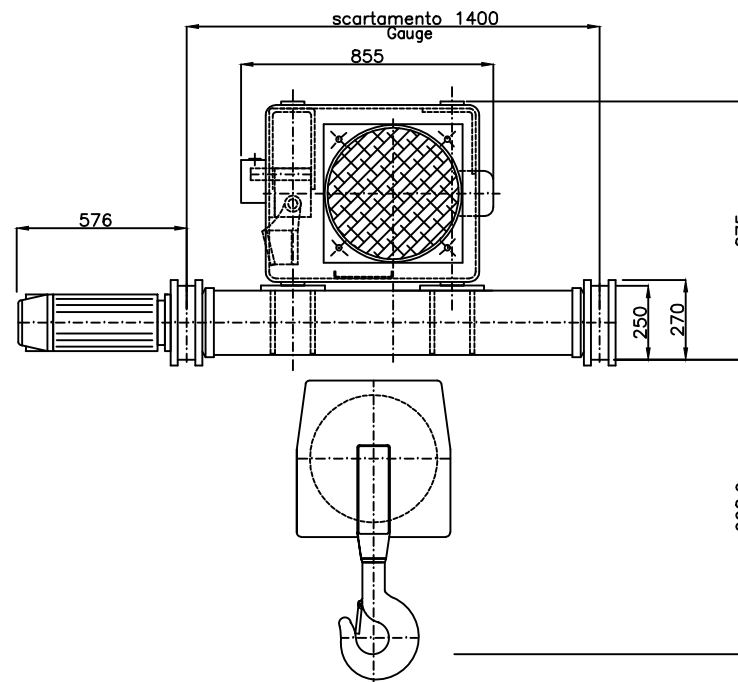

## Caratteristiche generali : General characteristics

Portata max Max capacity	12500	Kg.
Corsa gancio Hook lift	20	m.
Tensione : Voltage :	400V - 50 Hz	
Velocità di sollevamento Lifting speed	6.0/1.5	m/min.
Velocità di traslazione trolley speed	16/5.3	m/min.
Potenza motore di sollevamento Hoist motor power	13/3	kW.
Potenza motore di traslazione Trolley motor power	0.55/0.18	kW.
Assorbimento motore di sollevamento Hoist motor absorbment	32/40	A.
Assorbimento motore di traslazione Trolley motor absorbment	1.9/1.6	A.

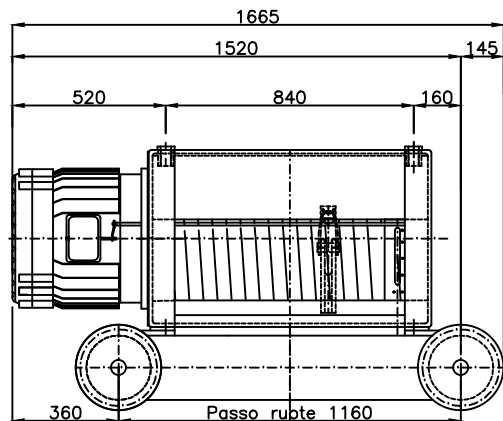
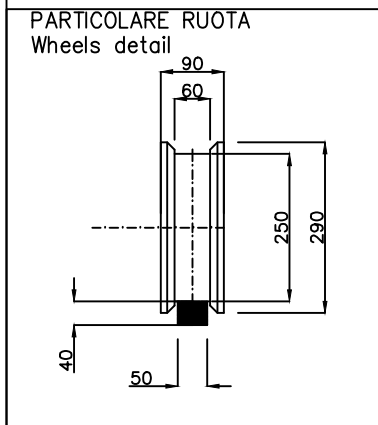
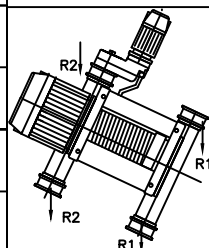
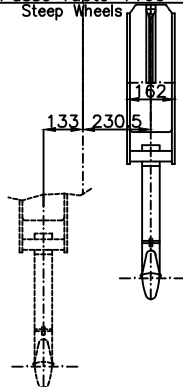

Reazioni statiche Valori statici (daN)		
R1	4836	daN
R2	2340	daN
Peso paranco : 1852 Kg		

PARANCO SERIE --- HOIST TYPE	MISIA  PARANCHI S.R.L.
XM963NS2H20A/53a	Revisone n. : Oggetto Rev:
DIMENSIONI GENERALI -- OVERALL DIMENSIONS	Scala 1 : 1
	DATA : 15/01/2012
	Dis. M.Ubbiali Visto. R.Brambilla