

Electric rope hoist MISIA type XM312VS4H7A/83 low headroom monorail trolley.

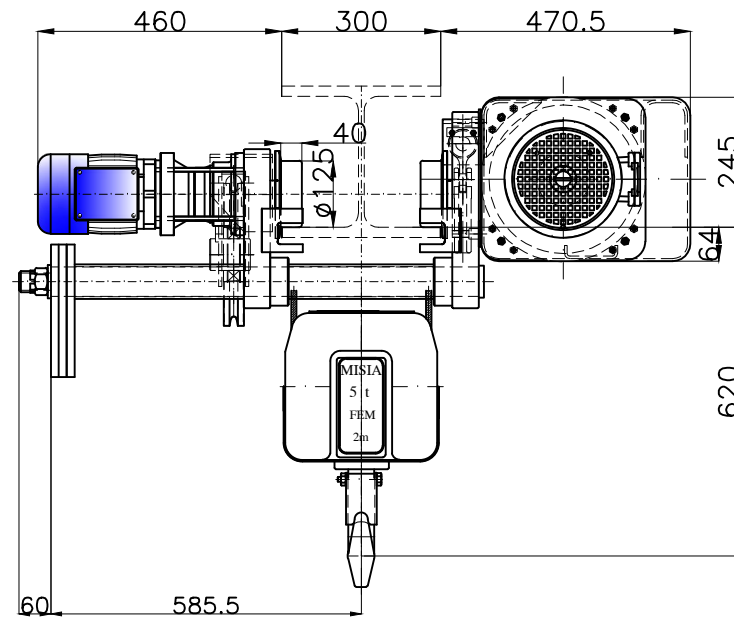

Dimensions with control panel (optional)

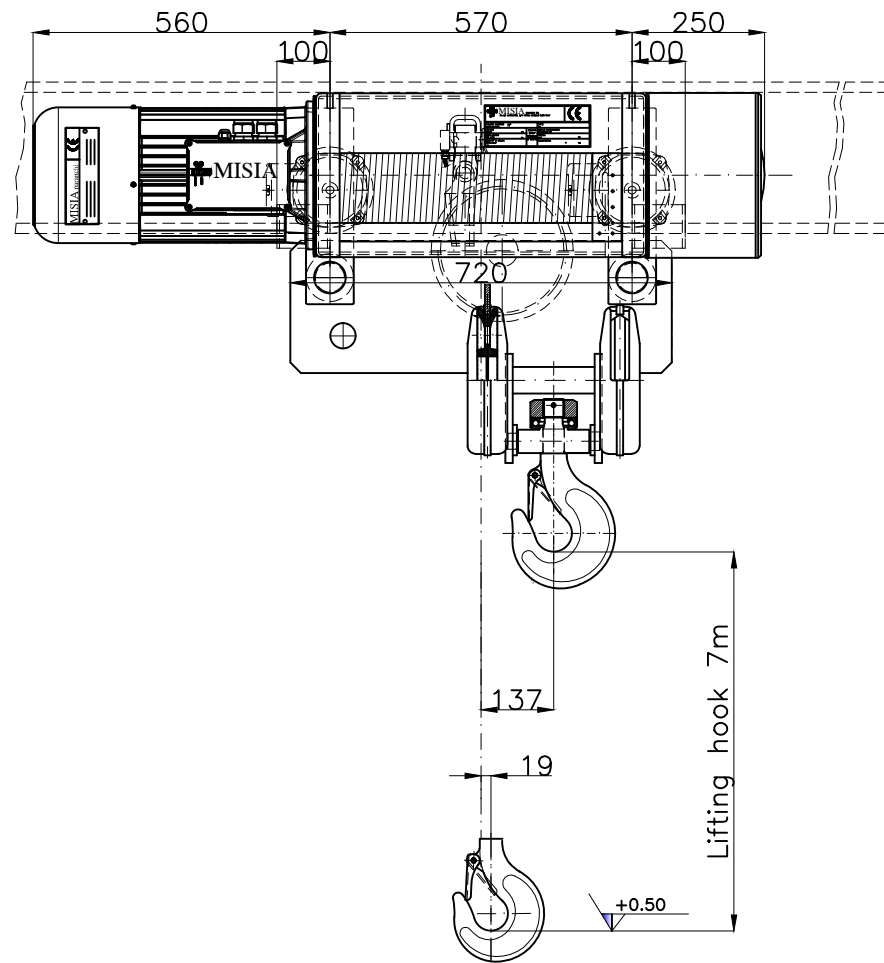
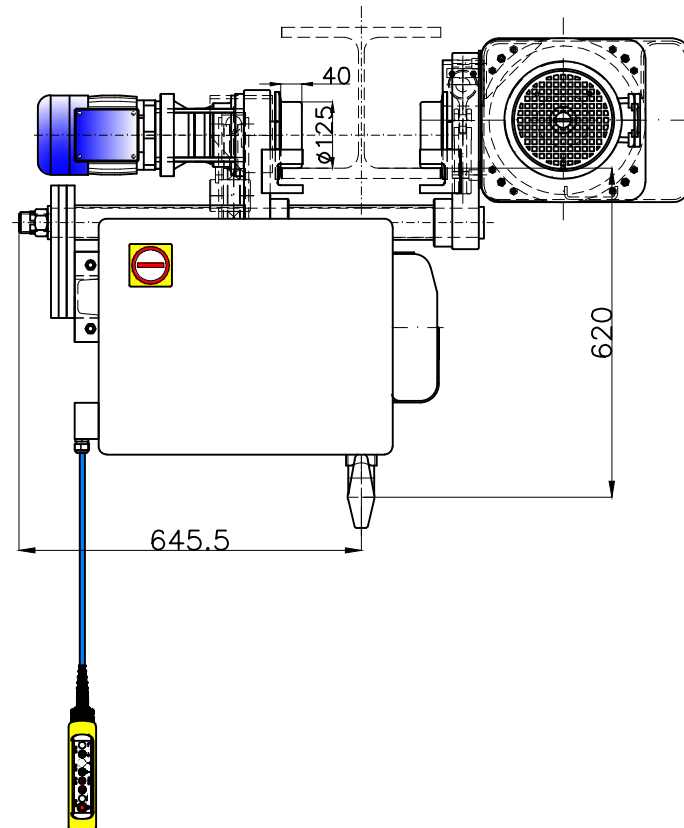
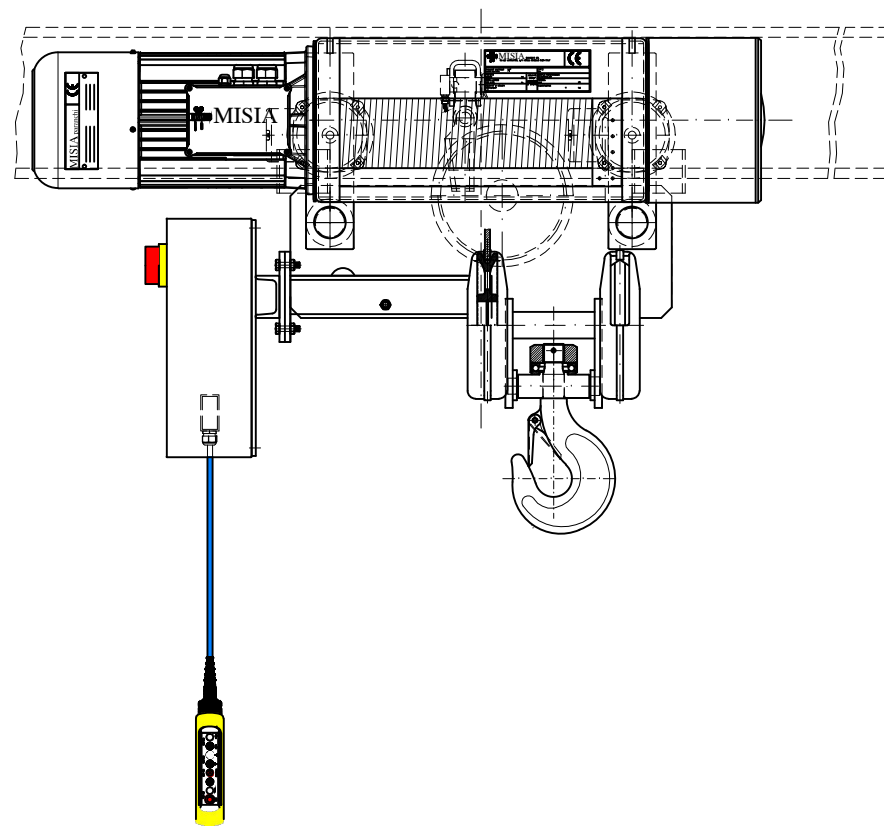

LATO MOTORE Motor side		LATO RIDUTTORE Reducer side	
Load on the single wheel R1/2 R2/2		Carico su ogni singola ruota R1/2 R2/2	
R1	3976	daN	
R2	1554	daN	
Peso paranco : 530 Kg			

NOTE :
 Ala trave standard Misia fino a 300mm
 Larghezza minima ala trave : 130 mm
 Per ali superiori a quelle indicate, la quota C (ingombro gancio) aumenta di 12mm ogni 10mm di larghezza ala trave.
 Beam size standard Misia up to 300mm
 Minimum size for beam : 130mm
 For wider beams dimensions than the indicated ones, the C dimension is 12mm more every 10mm of beam size more.

Caratteristiche generali
 General characteristics

Portata max Max capacity	5000	Kg.
Corsa gancio Hook lift	7	m.
Tensione : Voltage :	400V - 50 Hz	
Velocità di sollevamento Lifting speed	6.0/2.0	m/min.
Velocità di traslazione trolley speed	20/5	m/min.
Potenza motore di sollevamento Hoist motor power	5.8/1.9	kW.
Potenza motore di traslazione Trolley motor power	2x0.24/0.06	kW.
Assorbimento motore di sollevamento Hoist motor absorbment	12.7/9.1	A.
Assorbimento motore di traslazione Trolley motor absorbment	2x0.85/1.10	A.

Note :			
SCALA 1:1	Dis Contr.R.B. Appr R.B.	M.U.	
Data Emissione 13/09/14			
00	Electric rope hoist TYPE 83 Monorail low headroom 5t-7m LH	M.U.	R.B. 13/09/14
Rev.	DESCRIZIONE	Dis	Appr Data

	Paranco Misia tipo Serie XM312VS4H7A/83a
PARANCHI S.R.L.	type hoist type 83 item ...
	Misia number dwg/4397/r00
	00 Rev.