

Electric rope hoist MISIA type XM525NS2H10A/83 low headroom monorail trolley.

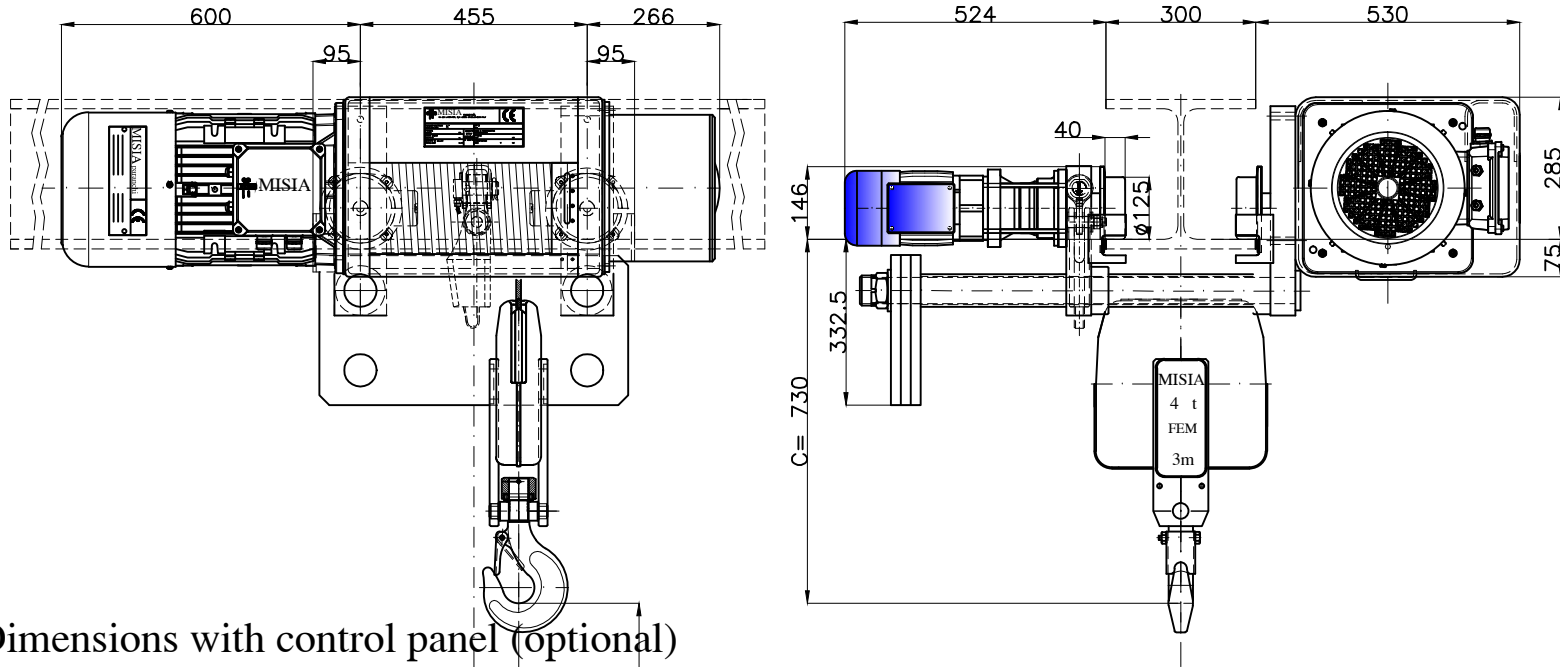

Dimensions with control panel (optional)

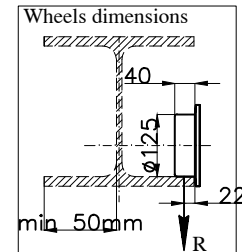

Dimensions with control panel (optional)

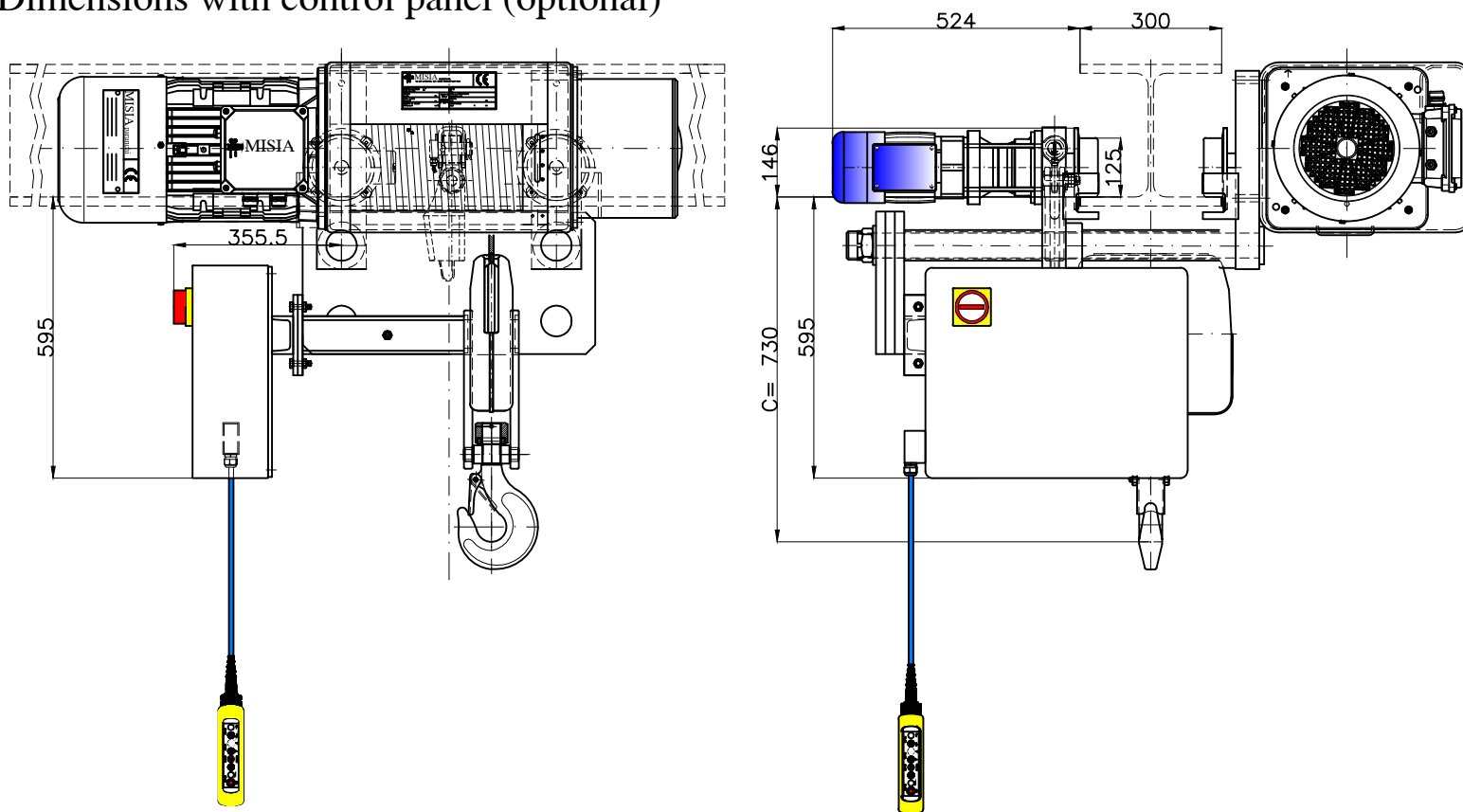

LATO MOTORE Motor side		LATO RIDUTTORE Reducer side	
Load on the single wheel R1/2 R2/2	R2	Carico su ogni singola ruota R1/2 R2/2	R1

Reazioni statiche Valori statici (daN)		
Static reactions values (daN)		
R1	3121	daN
R2	1524	daN
Peso paranco : 645 Kg		

NOTE :
 Ala trave standard Misia fino a 300mm
 Larghezza minima ala trave : 130 mm
 Per ali superiori a quelle indicate, la quota C (ingombro gancio) aumenta di 12mm ogni 10mm di larghezza ala trave.
 Beam size standard Misia up to 300mm
 Minimum size for beam : 130mm
 For wider beams dimensions than the indicated ones, the C dimension is 12mm more every 10mm of beam size more.

Caratteristiche generali
 General characteristics

Portata max Max capacity	4000	Kg.
Corsa gancio Hook lift	10	m.
Tensione : Voltage :	400V - 50 Hz	
Velocità di sollevamento Lifting speed	8/2.6	m/min.
Velocità di traslazione trolley speed	20/5	m/min.
Potenza motore di sollevamento Hoist motor power	8.0/2.6	kW.
Potenza motore di traslazione Trolley motor power	2x0.24/0.06	kW.
Assorbimento motore di sollevamento Hoist motor absorbment	17.4/18.7	A.
Assorbimento motore di traslazione Trolley motor absorbment	2x0.85/1.10	A.

Note :

00	Electric rope hoist TYPE 83 Monorail low headroom 4t-10m L.H	M.U.	R.B.	31/03/14		Data Emissione 31/03/14
Rev.	DESCRIZIONE	Dis	Appr	Data		

MISIA
 PARANCHI S.R.L.

Paranco Misia tipo
 Serie XM525NS2H10A/83a
 type hoist
 type 83
 item
 ...

Misia number
 dwg/4350/r00

00
 Rev.