

Electric rope hoist MISIA type XM525VS4H13A/83 low headroom monorail trolley.

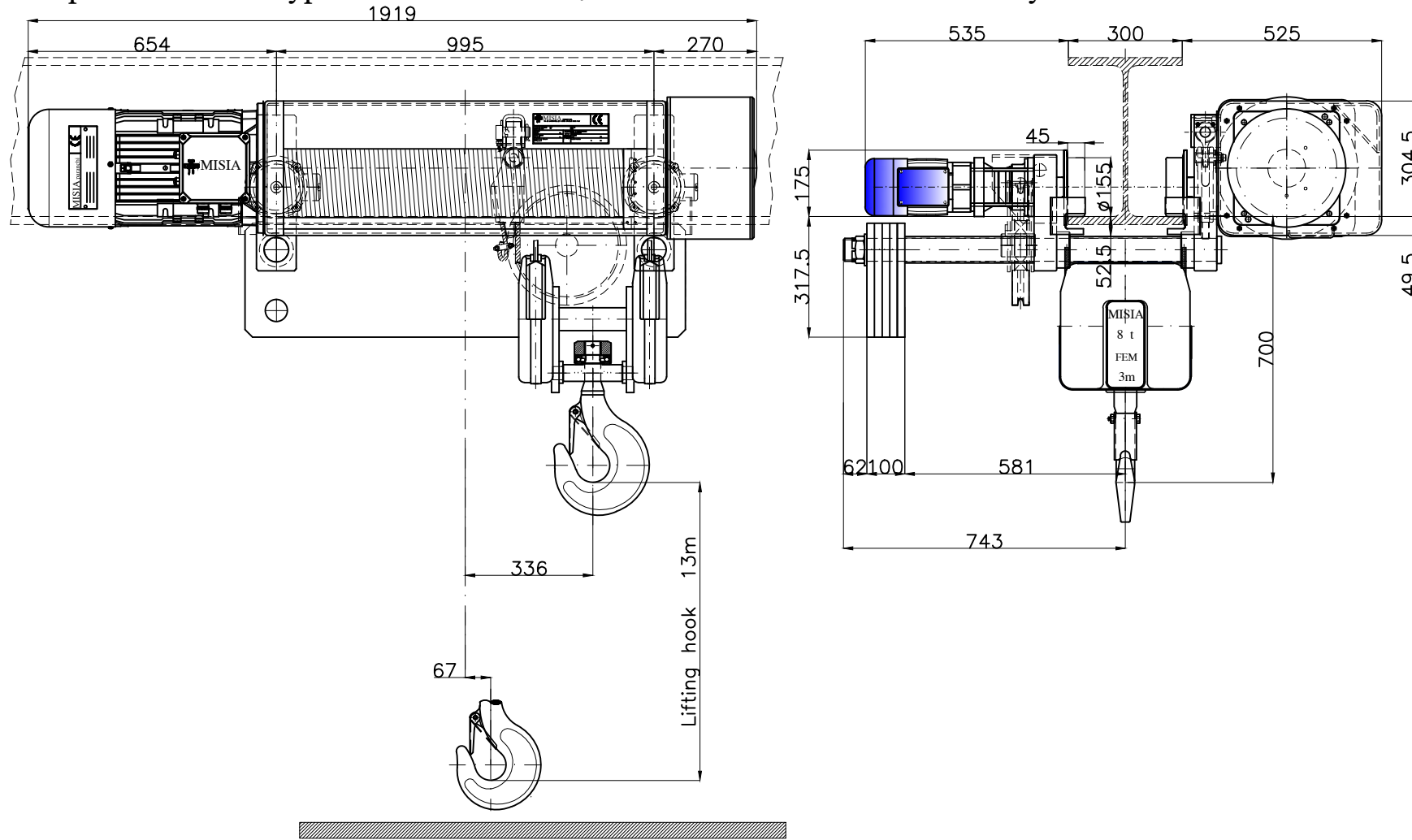

Dimensions with control panel (optional)

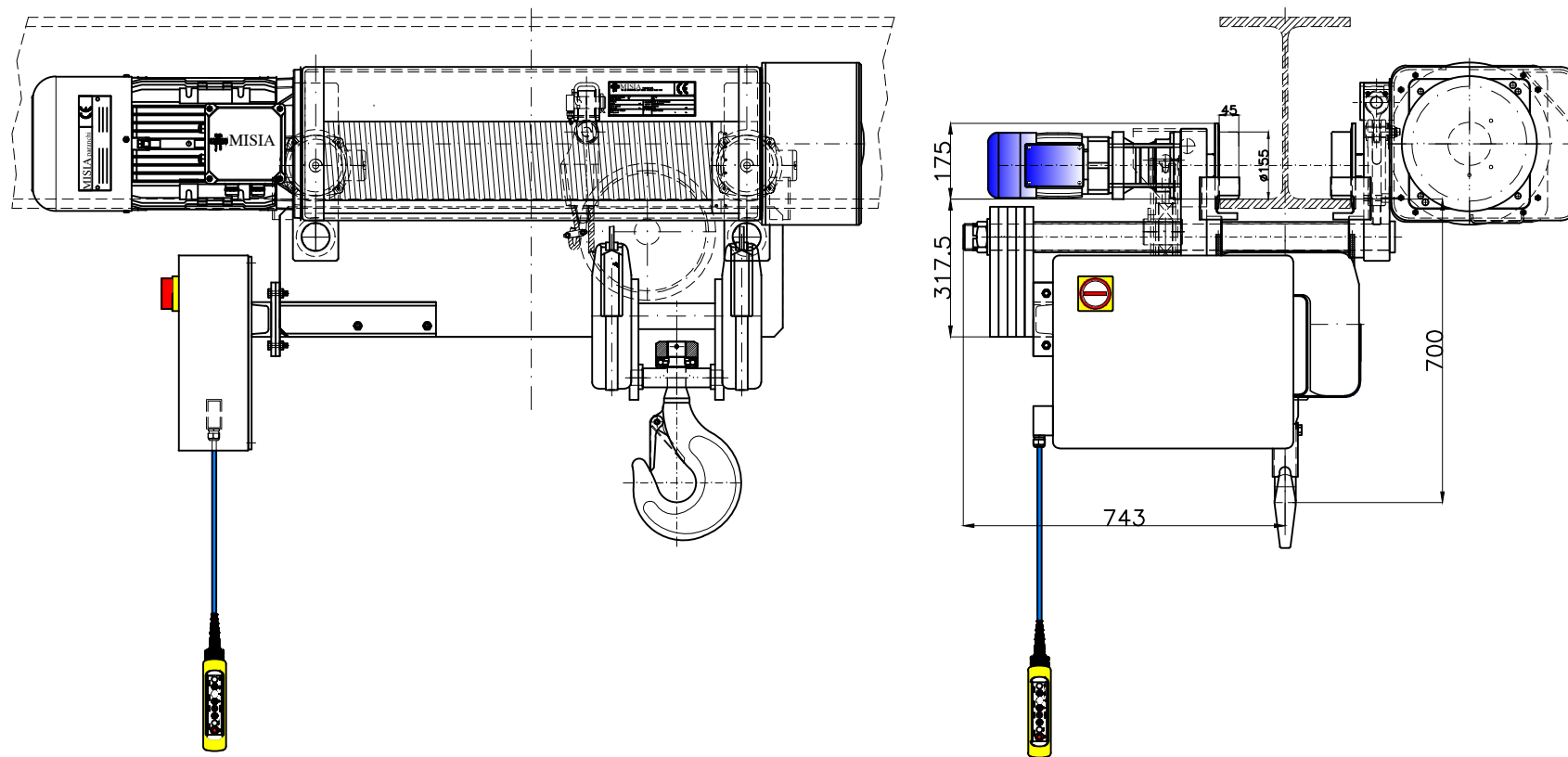

LATO MOTORE Motor side		LATO RIDUTTORE Reducer side	
Load on the single wheel R1/2 R2/2		Carico su ogni singola ruota R1/2 R2/2	
R1	7189	daN	
R2	1731	daN	
Peso paranco : 920 Kg			

NOTE :
 Ala trave standard Misia fino a 300mm
 Larghezza minima ala trave : 130 mm
 Per ali superiori a quelle indicate, la quota C (ingombro gancio) aumenta di 12mm ogni 10mm di larghezza ala trave.
 Beam size standard Misia up to 300mm
 Minimum size for beam : 130mm
 For wider beams dimensions than the indicated ones, the C dimension is 12mm more every 10mm of beam size more.

Caratteristiche generali
 General characteristics

Portata max Max capacity	8000	Kg.
Corsa gancio Hook lift	13	m.
Tensione : Voltage :	400V - 50 Hz	
Velocità di sollevamento Lifting speed	6/2	m/min.
Velocità di traslazione trolley speed	20/5	m/min.
Potenza motore di sollevamento Hoist motor power	12/4	kW.
Potenza motore di traslazione Trolley motor power	2x0.30/0.06	kW.
Assorbimento motore di sollevamento Hoist motor absorbment	29.2/29.0	A.
Assorbimento motore di traslazione Trolley motor absorbment	2x0.85/1.10	A.

Note :			
SCALA 1:1	Dis Contr	M.U. R.B.	
		Appr	R.B.
Data Emissione			14/09/14
00	Electric rope hoist TYPE 83 Monorail low headroom 8t-13m L.H	M.U.	R.B. 14/09/14
Rev.	DESCRIZIONE	Dis	Appr Data

 PARANCHI S.R.L.	Paranco Misia tipo Serie XM525VS4H13A/83a type hoist type 83 item ...	Misia number dwg/4417/r00	00 Rev.
---------------------	--	------------------------------	------------